

RADIAL DRILL

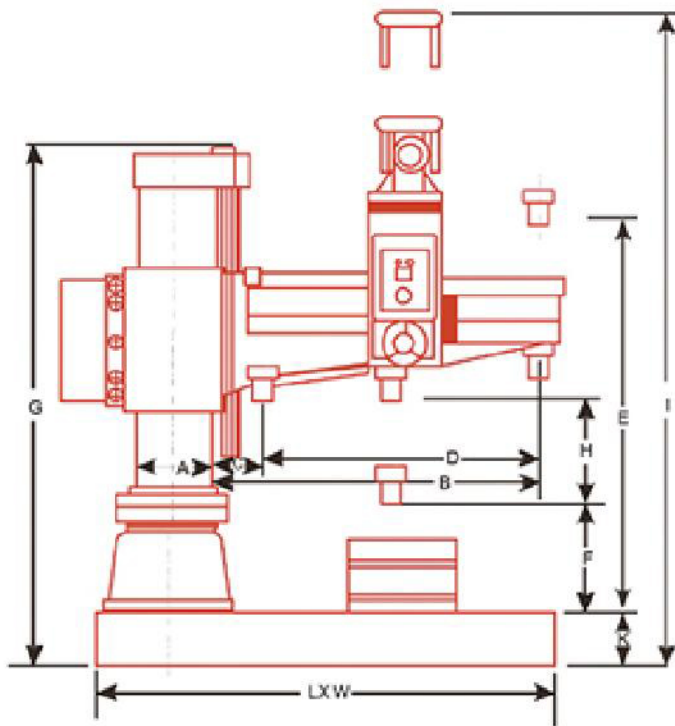

Standard accessories

- Tools 1 set
- Cooling pump 1 set
- Lamp 1 set
- Table 1 set

Optional accessories

- Drill taper set
- Drill vise

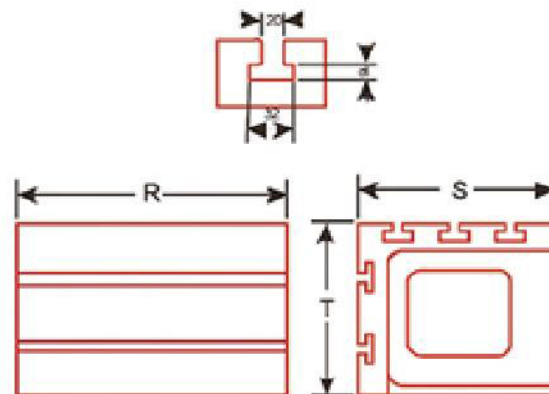

Unit:mm

| ITEM | | | SD-750 | SD-900 | SD-1100 | SD-1280H |
|---|-----------|-----------|--------------------|--------------------|--------------------|--------------------|
| Capacity | Drilling | Steel | 38 | 38 | Ø50 | Ø50 |
| | | cast iron | 50 | 50 | Ø60 | Ø60 |
| | Tapping | Steel | 25 | 25 | Ø30 | Ø30 |
| | | cast iron | 32 | 32 | Ø38 | Ø38 |
| Boring | Steel | 75 | 75 | Ø85 | Ø85 | |
| | cast iron | 105 | 105 | Ø120 | Ø120 | |
| Spindle stroke | | H | 200 | 200 | 250 | 250 |
| Size of morse Taer | | | MT4 | MT4 | MT4 | MT4 |
| Spindle speed | | 60HZ | 88-1500(6) | 88-1500(6) | 44-1500(12) | 44-1500(12) |
| | | 50HZ | 73-1250(6) | 73-1250(6) | 36-1250(12) | 36-1250(12) |
| Spindle Feeds | | | (0.05/0.09/0.15) | (0.05/0.09/0.15) | (0.05/0.09/0.15) | (0.005/0.09/0.15) |
| Column Diameter | | A | 210 | 210 | 300 | 300(11 7/8 ") |
| Max.distance,column sarace spindle center | | B | 765 | 910 | 1150 | 1250 |
| Min.distance,column sarace spindle center | | C | 290 | 290 | 330 | 330 |
| Horional Travel of Meadstock | | D | 500 | 650 | 810 | 920 |
| Max.distance,base to spindle | | E | 1110 | 1110 | 1210 | 1210 |
| Min.distance,base to spindle | | F | 282 | 282 | 290 | 290 |
| Overall height of column | | G | 1850 | 1850 | 2140 | 2140 |
| Machine height of column (Max.) | | I | 2175 | 2175 | 2585 | 2585 |
| Dimensions of hase (LXWXK) | | | 1280 x 640 x 150 | 1280 x 640 x 150 | 1800 x800 x 170 | 1800 x800 x 170 |
| Effective area of table (RXSXT) | | | 550 x 405 x315 | 550 x 405 x315 | 650 x 500 x 410 | 650 x 500 x 410 |
| Spindle drive motor [HP] | | | 2HP | 2HP | 3HP(4P×8P) | 3HP(4P × 8P) |
| Arm elevation motor [HP] | | | 1HP | 1HP | 2HP | 2HP |
| Coolant pump [HP] | | | 1/8HP | 1/8HP | 1/8HP | 1/8HP |
| Oil motor [HP] | | | | | | 1HP |
| Net weight -Approx [kg] | | | 1100kgs / 1170kgs | 1100kgs / 1170kgs | 2000kgs | 2050kgs |
| Groos weight-Approx [kg] | | | 1200kgs / 1270 kgs | 1200kgs / 1270 kgs | 2100 kgs | 2150 kgs |
| Measurement-packing [L x W x H] | | | 1430 x 820 x 2060 | 1580 x 820 x2060 | 2010 x 1050 x 2230 | 2290 x 1100 x 2230 |